

RECOMMENDED PCB LAYOUT(TOP VIEW)  
THICKNESS 1.0±0.10MM;DEFAULT TOLERANCE:±0.05

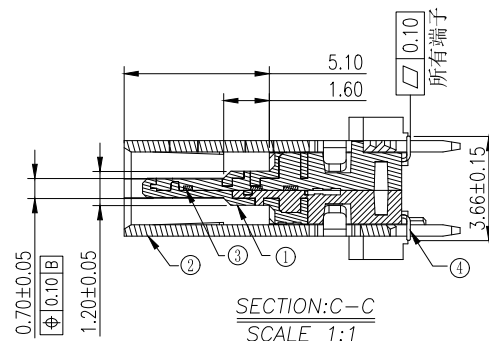
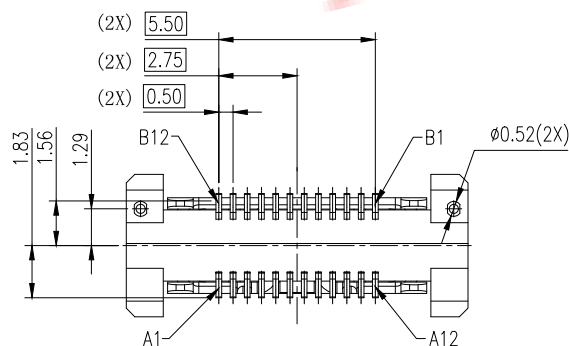
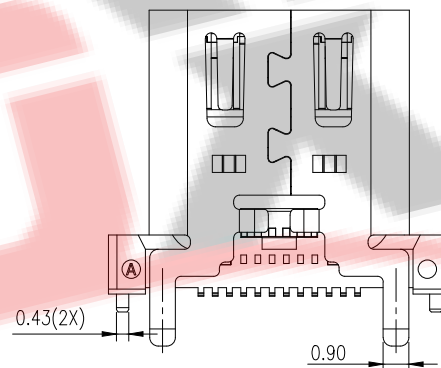
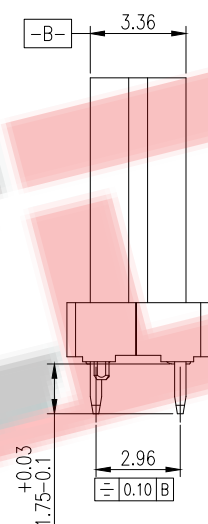
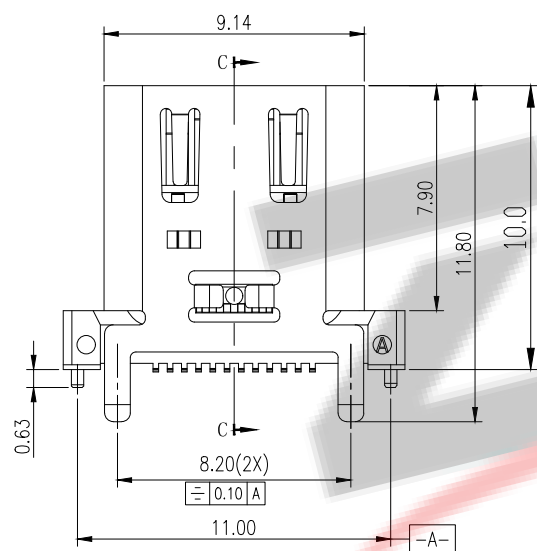

SECTION:C-C  
SCALE 1:1

NOTE:

- 1.MATERIAL SPECIFICATION:
  - 1.HOUSING:PA9T,UL94 V-0.
  - 2.TERMINAL: COPPER ALLOY(C2680)
  - 3.MID PLATE: STAINLESS STEEL(SUS301)
  - 4.FRONT SHELL: STAINLESS STEEL(SUS304)
- 2.PLATING SPECIFICATION:
  - 2-1.TERMINAL:
    - Ni 50u" MIN. UNDER PLATED OVER ALL.
    - Au PLATED ON THE FUNCTIONAL AREA OF CONTACT.
    - (GOLD PLATING THICKNESS FOLLOW THE P/N)
    - PLATING SPECIFICATIONS OF THE SOLDER AREA FOLLOW THE P/N
  - 2-2.SHELL:
    - Ni 50u" MIN. UNDER PLATED OVER ALL.
  - 2-3.MID PLATE:
    - CLEAR ONLY
- 3.MECHANICAL PERFORMANCE,
  - 3-1.INSERTION FORCE: 0.5~2.0kgf.
  - 3-2.REMOVAL FORCE: 0.8kgf~2.0kgf.
  - 3-3.DURABILITY: 10000 CYCLES.
- 4.ELECTRICAL PERFORMANCE,
  - 4-1. VOLTAGE RATING:5 V DC/AC (RMS. max)  
CURRENT RATING:3 AMPS. FOR TOTAL VBUS/GND PINS;  
1.25AMPS FOR CC PIN,0.25 AMPS. FOR ALL OTHER CONTACT.
  - 4-2. LLCR:
    - VBUS & GND PINS AND OTHER PINS: 40mΩ/PIN MAX.
    - SHIELD: 50mΩ/MAX.
    - LLCR MAX. CHANGE OF ALL PINS: 10mΩ.
  - 4-3.INSULATION RESISTANCE: 100MΩ MIN
  - 4-4.DIELECTRIC WITHSTAND VOLTAGE,AC 100V FOR 1 MINUTE.
5. ENVIRONMENTAL PERFORMANCE:
  - OPERATING TEMPERATURE: -25°C~+85°C.
- 6.IR REFLOW:
  - THE PEAK TEMPERATURE ON THE BOARD SHALL BE MAINTAINED FOR 10 SECONDS AT 260°C.

**ZDX** 深圳市兆达鑫科技有限公司  
Shenzhen zhaodaxin Technology Co., Ltd

TITLE: TYPE-C/F 24PIN直立式SMT H=10.0MM  
带弹片  
工程图

PART NO.:ZDX-CFLS242FY01  
TEL:0755-29888153  
WEB: <http://www.szzdjmkj.com/>

THIRD ANGLE PROJECTION 	UNIT:	SCALE:	SIZE:	SHEET:
	mm	1:1	A4	1/3

RoHS Compliant

Halogen Free

customer drawing

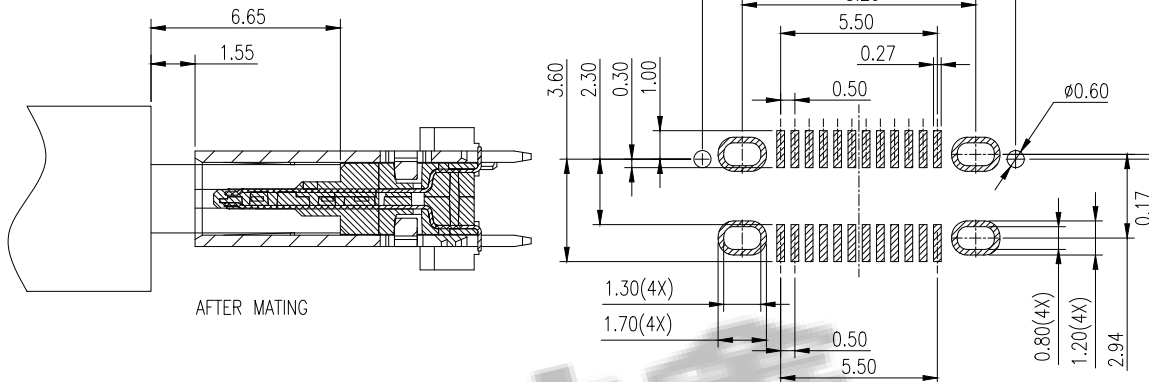
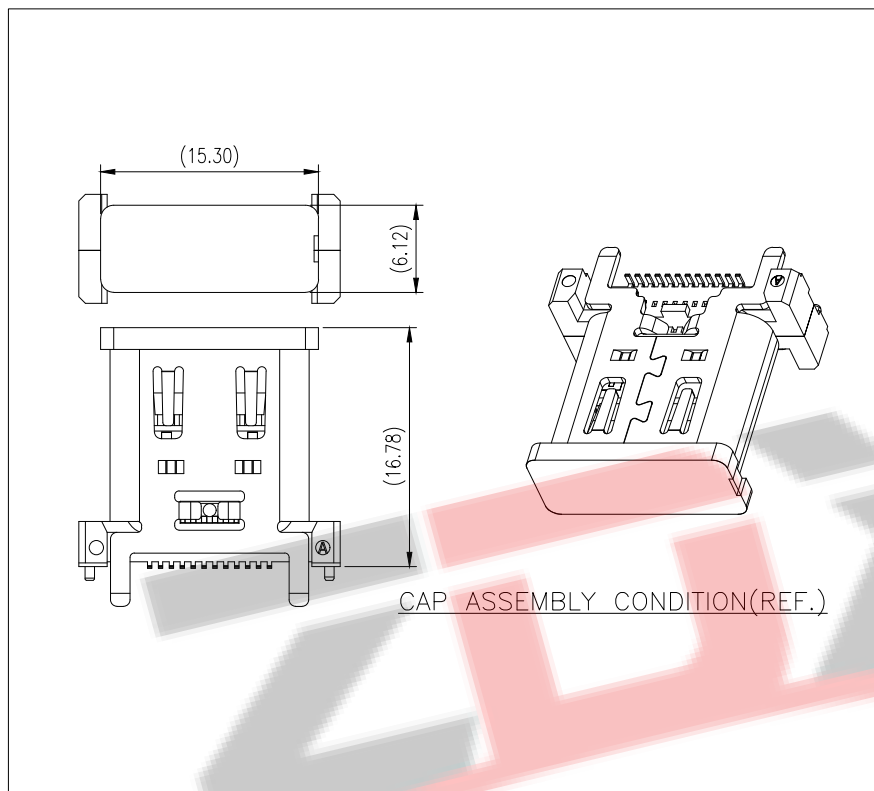

RECOMMENDED PCB LAYOUT(TOP VIEW)  
THICKNESS 1.0±0.10MM;DEFAULT TOLERANCE:±0.05

USB TYPE-C PIN ASSIGNMENTS

PIN NUMBER	SIGNAL NAME	PIN NUMBER	SIGNAL NAME
A1	GND	B12	GND
A2	SSTXp1	B11	SSRXp1
A3	SSTXn1	B10	SSRXn1
A4	VBUS	B9	Vbus
A5	CC1	B8	SBU2
A6	Dp1	B7	Dn2
A7	Dn1	B6	Dp2
A8	SBU1	B5	CC2
A9	Vbus	B4	Vbus
A10	SSRXn2	B3	SSTXn2
A11	SSRXp2	B2	SSTXp2
A12	GND	B1	GND

料号编码:

XXX - XX XX XX X X XXXX

公司名称  
产品类别  
A-USBA F-母座  
B-USBB M-公头  
C-USBC  
M-MICRO  
N-MINI

产品上板形态  
L-立式  
M-卧式

S-贴片  
D-插件  
C-沉板  
J-夹板  
H-焊线  
XF-防水系列产品  
X=上板类型

PIN 数  
06:6PIN  
16:16PIN  
24:24PIN  
以此产品为准

包装方式  
1. TRAY (吸塑盒)  
2. TAPE (编带)  
3. TAPE (袋装)

产品识别流水码

**ZDX** 深圳市兆达鑫科技有限公司  
Shenzhen zhaodaxin Technology Co., Ltd

TITLE: TYPE-C/F 24PIN直立式SMT H=10.0MM 带弹片 工程图	PART NO.:ZDX-CFLS242FY01			
	TEL:0755-29888153			
	WEB: http://www.szzdjmj.com/			
THIRD ANGLE PROJECTION 	UNIT: mm	SCALE: 1:1	SIZE: A4	SHEET: 2/3

RoHS Compliant

Halogen Free

customer drawing

□ Packing Notes:

1. Reel : 400Pcs/Reel.
2. Carton : 3200Pcs/8 Reel/Carton.

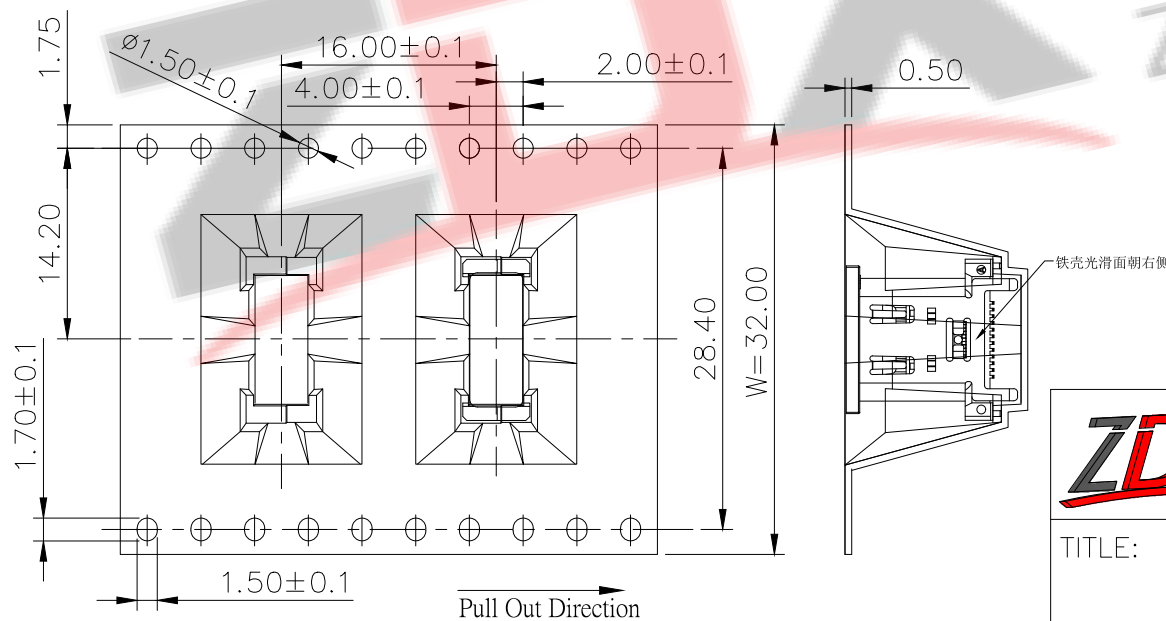
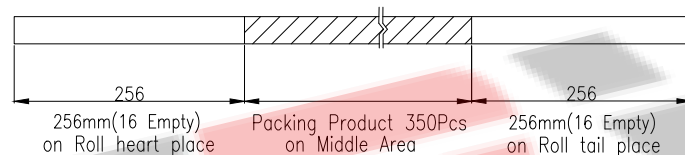
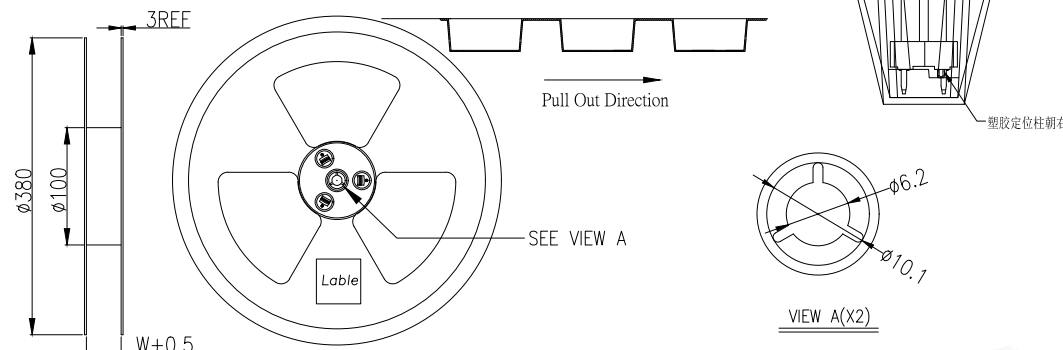

- 1) Seal the carton with TAPE.
- 2) Attach the label to the side of the carton

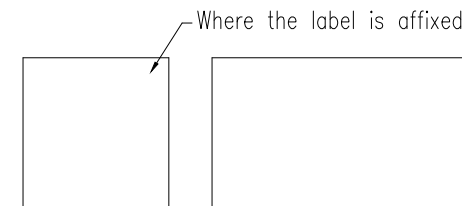

NOTES:

(REMARK)

- 1). If there are any unfilled boxes, they must be filled with buffer material.
- 2). Handle with care during handling.
- 3). Do not pile up too much or have heavy pressure during transportation.
- 4). The upper belt must be smooth when pasting the lower belt, and no bubbles appear at the pasting place.

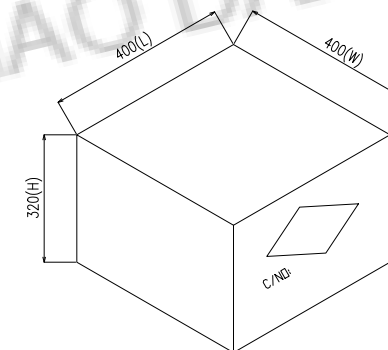

**ZDX** 深圳市兆达鑫科技有限公司  
Shenzhen zhaodaxin Technology Co., Ltd

TITLE:		PART NO.:ZDX-CFLS242FY01		
PACKING DRAWING		TEL:0755-29888153		
工程图		WEB: <a href="http://www.szzdjmkj.com/">http://www.szzdjmkj.com/</a>		
THIRD ANGLE PROJECTION	UNIT:	SCALE:	SIZE:	SHEET:
	mm	1:1	A4	3/3